

4

3

2

1

ASK IF IN DOUBT!

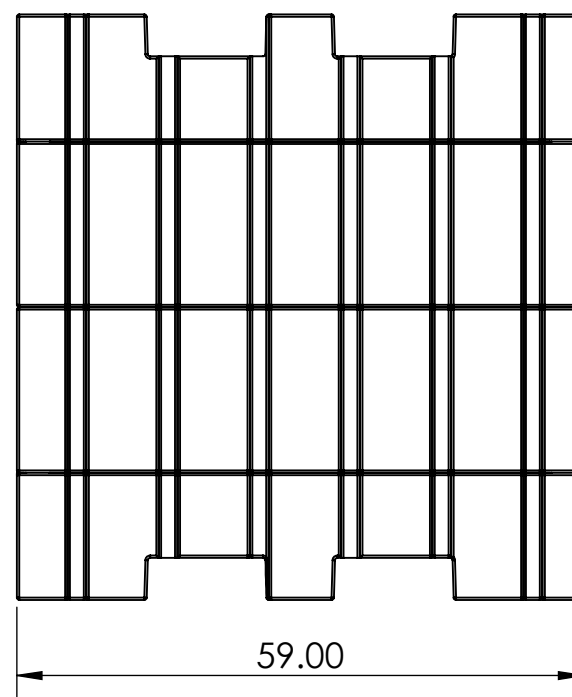
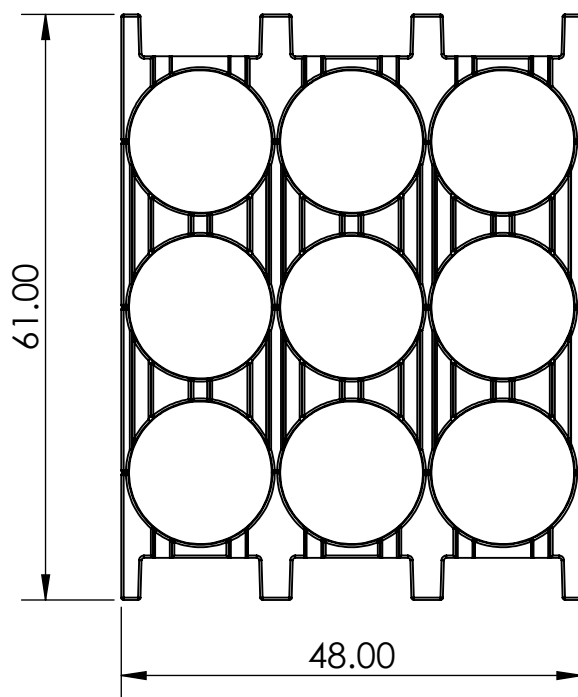
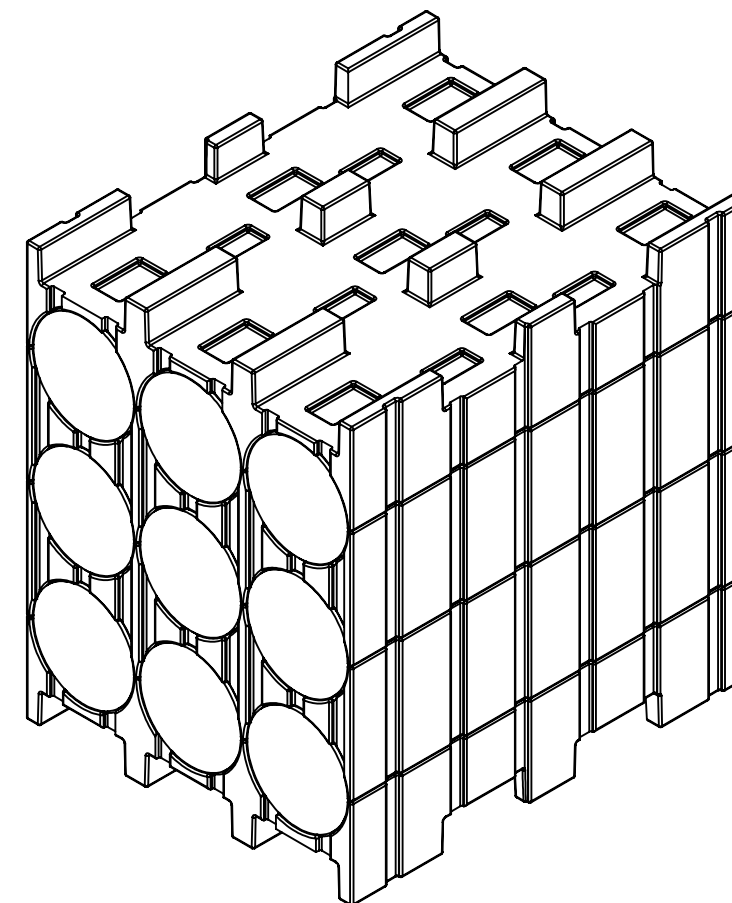
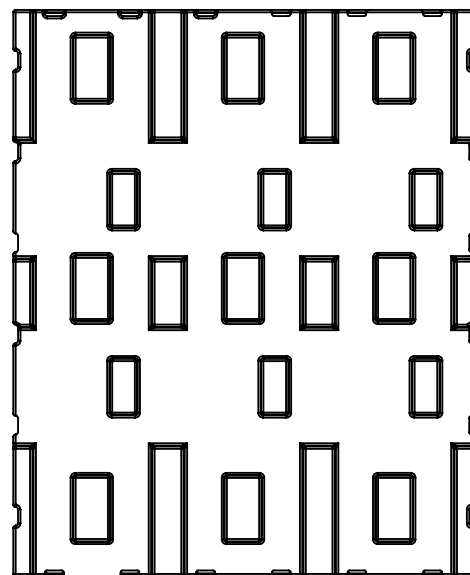

UNLESS OTHERWISE SPECIFIED DIM ARE IN INCHES TOL ON ANGLES $\pm .5^\circ$ 2 PL ± 0.02 3 PL ± 0.008 FRACTION $\pm 1/64$ INTERPRET DIM AND TOL PER ASME Y14.5 - 2018	MATERIAL		 HPP Advisors Inc info@hppadvisors.com <small>This drawing and any information or descriptive material set out on it are the confidential and copyright property of HPP Advisors, Inc© and MUST NOT BE DISCLOSED, COPIED, LOANED in whole or part or used for any purpose without the written permission of HPP Advisors, Inc.</small>			
	FINISH		DOCUMENT STATUS		TITLE	
	WEIGHT		NOT TO MANUFACTURE		5915 PALLET ASSEMBLY	
	PROJECTION METHOD		APPROVED BY	APPROVED DATE		
	THIRD ANGLE		-	-		
	DRAWN BY	DRAWN BY	DWG NO.	PART NO.		
	P. Zala	13-10-2022	5915-33AS	5915-33AS		
	SHEET SIZE	SCALE	REV	SHEET		
	B	1:20	A	1/1		

4

3

2

1

B

A

B

A