

4

3

2

1

ASK IF IN DOUBT!

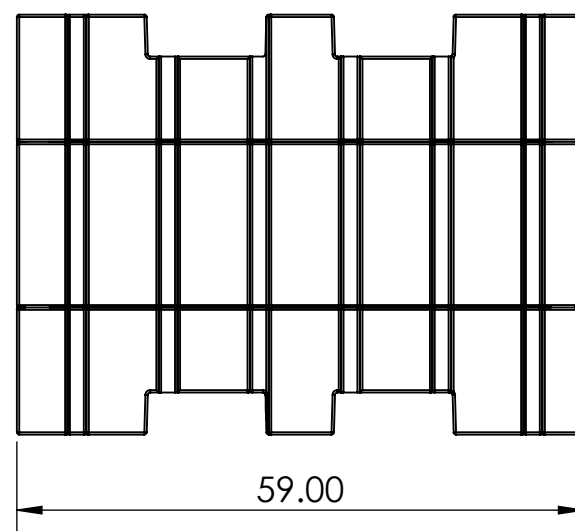
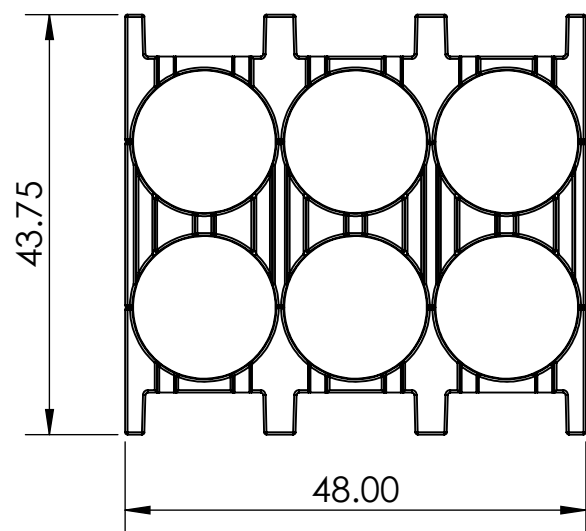
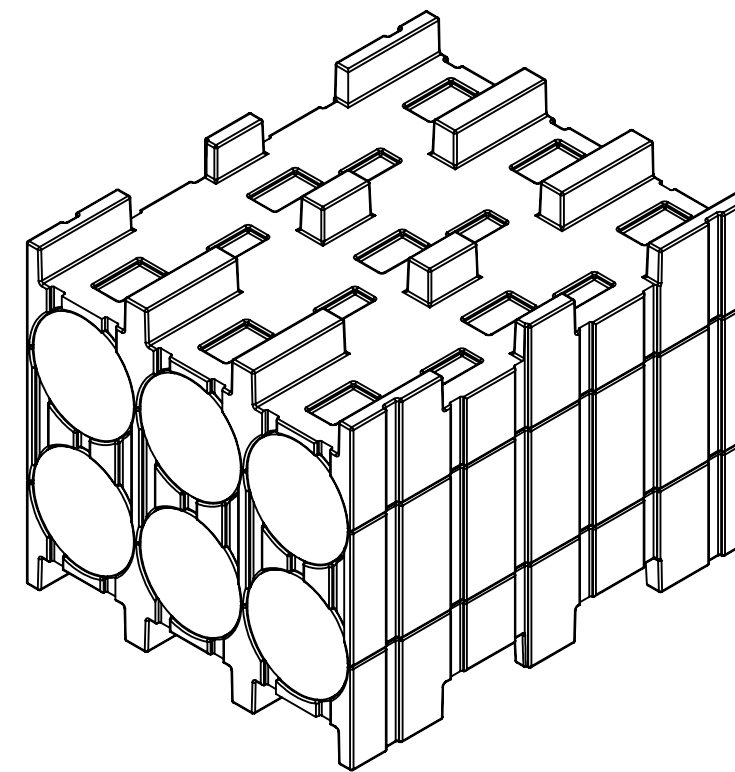
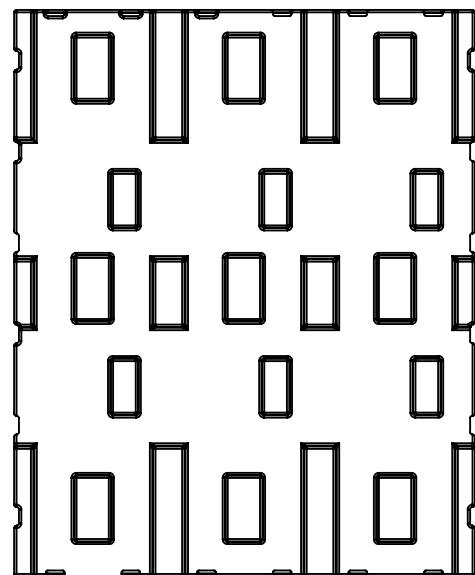

UNLESS OTHERWISE SPECIFIED DIM ARE IN INCHES TOL ON ANGLES $\pm .5^\circ$ 2 PL ± 0.02 3 PL ± 0.008 FRACTION $\pm 1/64$ INTERPRET DIM AND TOL PER ASME Y14.5 - 2018	MATERIAL		 HPP Advisors Inc info@hppadvisors.com <small>This drawing and any information or descriptive material set out on it are the confidential and copyright property of HPP Advisors, Inc© and MUST NOT BE DISCLOSED, COPIED, LOANED in whole or part or used for any purpose without the written permission of HPP Advisors, Inc.</small>		TITLE	
	FINISH				5915 PALLET ASSEMBLY	
	WEIGHT		DOCUMENT STATUS		APPROVED BY	
	PROJECTION METHOD		NOT TO MANUFACTURE		APPROVED DATE	
	THIRD ANGLE		-		-	
		DRAWN BY	DRAWN BY	DWG NO.	PART NO.	
		P. Zala	13-10-2022	5915-32AS	5915-32AS	
		SHEET SIZE	SCALE	REV	SHEET	
		B	1:20	A	1/1	

4

3

2

1